



PART NUMBER 1030L-11C
 ITEM NAME 1030 NM LASER

PRODUCT DATASHEET



DESCRIPTION

1029 nm nanosecond laser module is a turnkey laser featuring high pulse energy and a pulse duration of less than 2 nanoseconds. High pulse energy and compact package make this laser suitable for Light-Induced Breakdown Spectroscopy (LIBS) applications, as well as marking.

Current configurations in production:

Variant	Pulse duration, ns	Pulse energy, μJ	Peak power, kW	Repetition rate, kHz
1	1.3	50 to 60	38 to 46	10
2	1.5	100	67	2 to 3

**Other parameters can be developed based on customer specifications. Please refer to the table below for possible parameter ranges.*

CARACTÉRISTIQUES

Specifications updated: 23 June 2023

Parameter	Minimum Value	Typical Value	Maximum Value
Central wavelength, nm	1028	1030	1032
Longitudinal modes	-	Multiple	-
Spectral line width FWHM, nm	-	0.7	1
Output power, mW	-	As per request ¹	500
Pulse duration, ns (FWHM) (polarized version)	1.4	1.5	1.8
Pulse duration, ns (FWHM) (non-polarized version)	1.1	1.2	1.5
Repetition rate, kHz (depending on pulse energy)	1.5	As per request	2.5
Pulse energy, μJ	-	As per request	100
Power stability, % (RMS, 8 hrs)	-	0.5 ²	1
Pulse-to-pulse stability (RMS of peaks)	-	10	30
Transversal modes	-	TEM ₀₀	-
Beam width (1/e ²), mm	-	1.1 ³	-
Beam height (1/e ²), mm	-	1.2	-
Horizontal beam divergence, mrad	-	1.2	-
Vertical beam divergence, mrad	-	1.1	-
M ² effective	-	1.3	1.5
Jitter, μs	-	20	50
Jitter, %	-	3	8
Control interface type	-	UART ⁴	-
Operation mode	-	APC (CW)	-
Input voltage, VDC	-	5	-

TYPICAL SPECTRUM

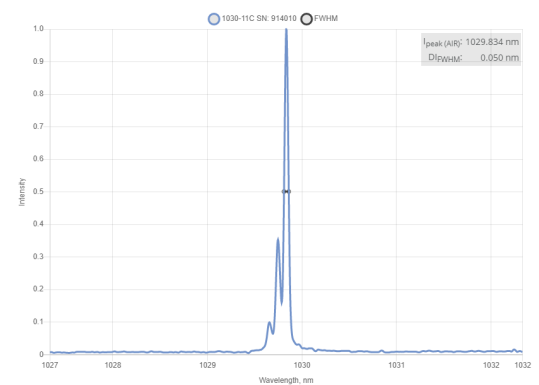

Typical spectrum of 1030 nm passive Q-Switch DPSS laser. Measured with 20 pm resolution.

TYPICAL NEAR FIELD

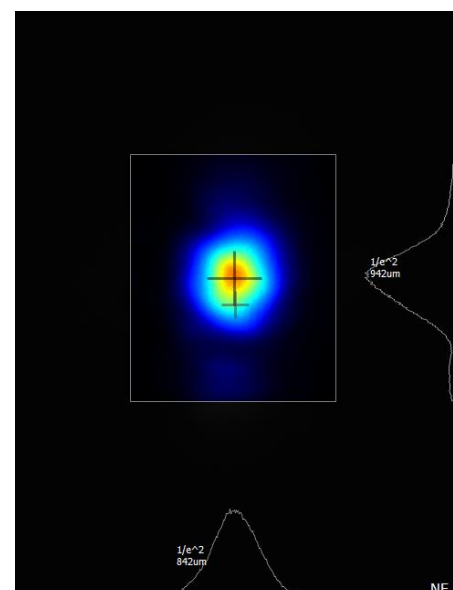

External power supply requirement	-	+5 V DC, 5A	-
Dimensions (LxWxH), mm	-	50 x 30 x 18 ⁵	-
Beam height from the base, mm	-	10.4	-
Heat-sinking requirement, °C/W	-	0.5	-
Optimum heatsink temperature, °C	-	20	-
Warm up time, mins (cold start)	-	10	-
Temperature stabilization	-	Internal TEC	-
Overheat protection	-	Yes	-
Storage temperature, °C (non-condensing)	-	-	-
Net weight, kg	-	0.29	-
Max. power consumption, W	-	25	-
Warranty, months (op. hrs)	-	14 (10000) ⁶	-
RoHS	-	Yes	-
CE compliance	-	- General Product Safety Directive (GPSD) 2001/95/EC - (EMC) Directive 2004/108/EC	-
Laser safety class	-	3B	-
OEM lasers are not compliant with	-	IEC60825-1:2014 (compliant using additional accessories)	-

TYPICAL FAR FIELD

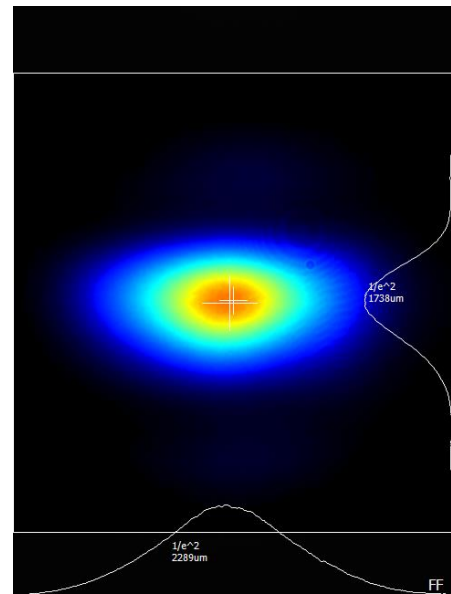

DRAWING

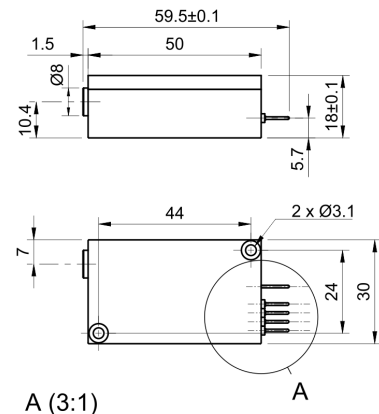

**MatchBox
Free-Space**

¹ The optical power can be tuned from virtually 0% to 100%. However, other specifications, such as central wavelength, power stability, noise, polarization ratio, beam shape, quality and circularity are not guaranteed at power levels other than factory preset power. Significantly worse power stability is to be expected at very low power levels, e.g. <3% from specified nominal power.

² The long term power test is carried out at constant laser body temperature (+/-0.1 °C) using an optical power meter with an input bandwidth of 10 Hz. The actual measurement rate has a period of about 20 seconds to 1 minute.

³ Beam width and height are measured at 0.45 m from output aperture.

⁴ Break-out-boxes AM-C8 and AM-C3 can be used for conversion of UART communication to either USB or RS232.

⁵ Excluding control interface pins and an output window/fiber assembly.

⁶ Whichever occurs first. The laser has an integrated operational hours counter.

Note: Product specifications are subject to change without prior notice to improve reliability, function or design or otherwise.